



SAA8122A

Digital Still Camera Processor (ImagIC family)

Rev. 03 — 22 November 2000

Objective specification

1. Description

The DSC SAA8122A is a high performance, low power, single-chip Million Instructions Per Second (MIPS) based signal processor, part of the ImagIC family, which is dedicated to image processing, compression, formatting and storage. The DSC SAA8122A is optimized for use with Philips range of CCDs (e.g: FXA1022, 2 Mpixels CCD), V-driver (TDA9991), CDS/PGA/ADC (TDA9952), allowing easy implementation of a complete system solution and fast development of high performance consumer digital still cameras.

The SAA8122A is designed as a single-chip device, able to perform all treatments and connections required for a wide range of Digital Still Cameras. Its embedded RISC CPU, for which the development environment is available, enables shorter development and validation cycles, as well as faster feature upgrade. Since one of the main objectives of the SAA8122A is addressing a wide range of CCD sensors, a DSP (with advanced embedded algorithm) for camera signal processing is integrated with a high level of programmability for pulses generation.

The JPEG core is hardware based in order to allow high-speed image data compression.

2. Features

2.1 General

- Supports a wide range of progressive CCDs (VGA, SVGA, QGA, XGA, EQGA), with RGB Bayer filters up to 2 Mpixels
- Performs an advanced RGB to YUV conversion
- Includes a smart measurement unit to speed up the control loop (focus, auto white balance, etc.)
- Supports a wide range of LCD and TV formats (both NTSC and PAL) with text insertion features
- Includes an embedded JPEG encoder/decoder unit
- Includes a MIPS PR3001 CPU, running at a frequency in a range from 12 to 28 MHz
- PRISC compatible PI-bus architecture, interrupt, power management, clock and reset architectures
- Includes a dedicated video bus supporting SDRAM memory for picture storage



PHILIPS

- Interface to ROM, DRAM, SRAM, flash and PC Card [Compact Flash and SSFDC (SmartMedia)]
- Integrated general purpose peripheral units like a UART, timers, an I²C-bus transceiver, ADC converters, RTC and I/O ports
- Includes USB and RS-232C communication interfaces.

2.2 External interfaces

- Two UART (RS-232) data ports with DMA capabilities (≤ 187.5 kbit/s) including hardware flow control RxD, TxD, RTS, CTS for modem support
- 32 general purpose, bidirectional I/O interface pins, the first 8 bits may also be used as interrupt inputs
- Two PWM outputs (8-bit resolution).

2.3 CPU related features

- 32-bit PR3001 core
- 1-kbyte data cache and 4-kbyte instruction cache
- Programmable low-power mode, including wake-up on interrupt
- Memory management unit [Translation Lookaside Buffer (TLB)]
- Two built in 24-bit general purpose timers and one 24-bit watchdog timer
- Real-time clock unit (active in sleep mode)
- On-chip 8-kbyte SRAM for storing code which needs fast execution
- Platform software based on real-time pSOS (plug-in Silicon Operating System).

2.4 DSP features

- Advanced colour reconstruction
- Programmable digital filters for noise reduction and contour enhancement
- 16 programmable measurement windows allowing to perform the measurements necessary for exposure, white balance and focus adjustment in a DSC system; available measurement outputs for exposure, white balance and focus control.

2.5 Pulse pattern generator features

- Programmable through dedicated PC-software, allowing to drive all CCDs currently present in the market, as well as CDS/AGC/ADC chips: up to 8×8 kpixels.

2.6 JPEG

- Fully ISO10918 compliant
- Supports Tiff, Exif 2.1, DCF & DPOF
- Quick compression (4 images/s for a 1.3 Mpixels resolution).

2.7 USB interface

- Fully compatible with USB.

2.8 Card interfaces

- Compatible with all SSFDC/CF cards on the market.

2.9 Bus

- Bus structure allows for parallel processing depending on software implementation, allowing easy system optimization.

2.10 SDRAM interface features

- Supports up to 128 Mbyte of SDRAM and 16-bit wide addresses
- Bus speed: 1 or 2 times CCD pixel clock
- 32-bit bus width.

3. Quick reference data

Table 1: Quick reference data

Symbol	Parameter	Conditions	Min	Typ	Max	Unit
V _{DDD}	digital supply voltage		[1] 3	3.3	3.6	V
V _{DDA}	analog supply current		[2] 3	3.3	3.6	V
I _P	total supply current	f _{clk} = 25 MHz	–	360	560	mA
V _I	input voltage					
	general		0	–	V _{DDD}	V
	5 V tolerant cells only		[3] 0	–	5.5	V
V _O	output voltage	output active	0	–	V _{DDD}	V
T _{amb}	ambient temperature		0	25	70	°C
f _{clk}	clock frequency		–	25	27	MHz

[1] The supplies considered as digital supply (V_{DDD}) are: V_{DDD}, V_{DDD(RTC)}.

[2] The supplies considered as analog supply (V_{DDA}) are: V_{DDA(SPLL)}, V_{DDA(PLL)}, V_{DDA(BG)}, V_{DDA(PPG1)}, V_{DDA(ADC)}, V_{DDA(OUTPUT1)}, V_{DDA(OUTPUT2)}, V_{DDA(LCDR)}, V_{DDA(LCDG)}, V_{DDA(LCDB)}, V_{DDA(DLL)}.

[3] Including voltage on outputs in 3-state mode; only valid when supply voltage is present.

4. Ordering information

Table 2: Ordering information

Type number	Package		Version
	Name	Description	
SAA8122AEL	LFBGA324	plastic low profile fine-pitch ball grid array package; 324 balls; body 16 × 16 × 1.2 mm	SOT571-1

5. Block diagram

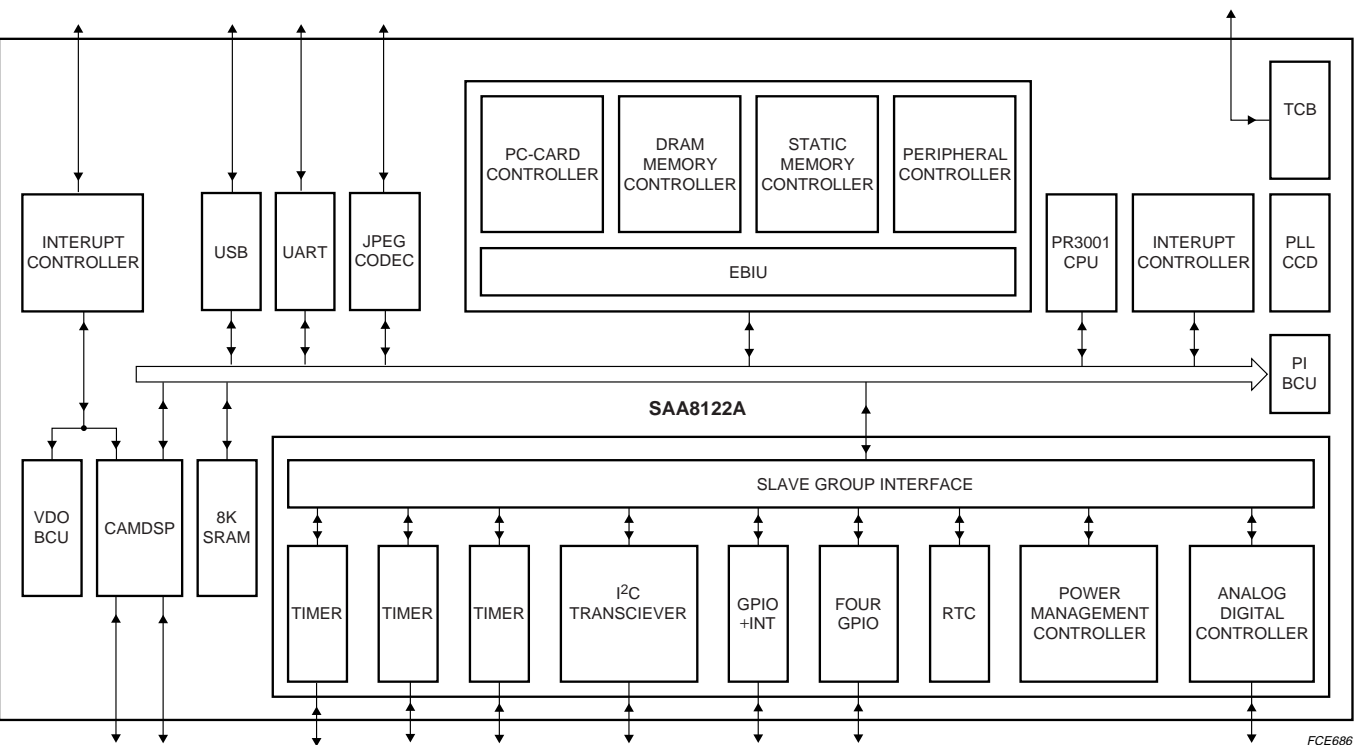

Fig 1. Block diagram.

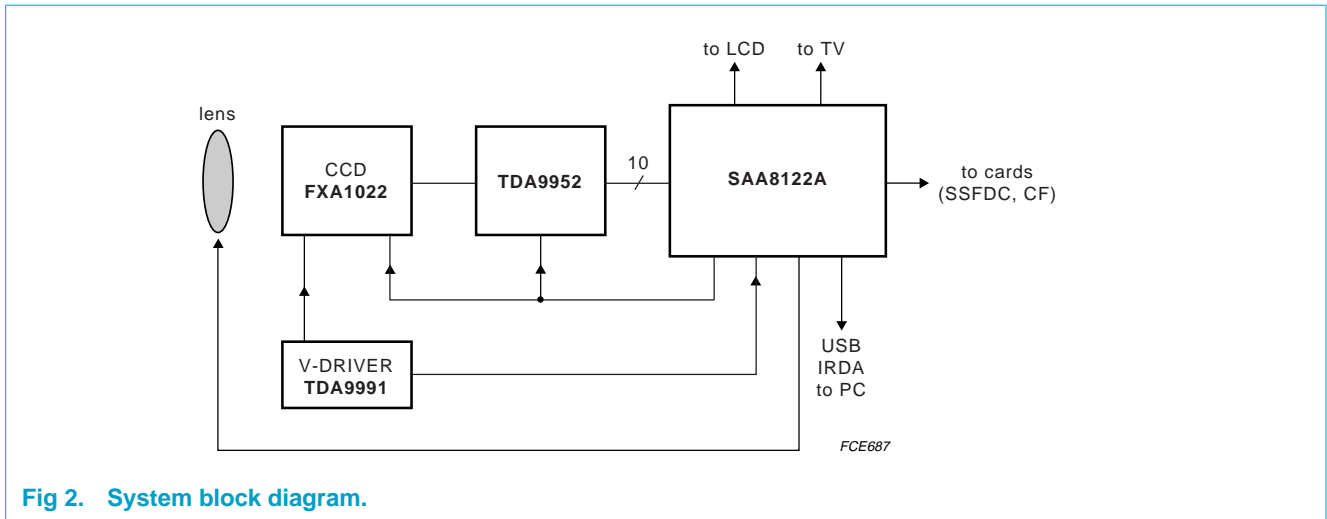

Fig 2. System block diagram.

6. Pinning information

6.1 Pinning

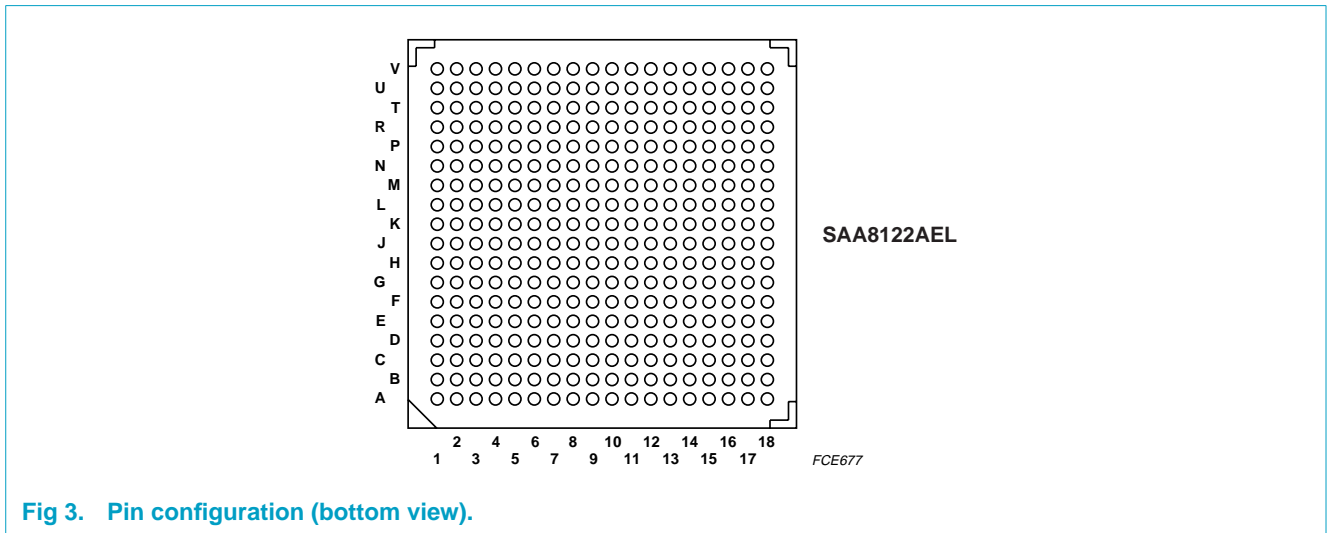

Fig 3. Pin configuration (bottom view).

6.2 Pin description

Table 3: Pin description

Symbol	Pin	Type	Description
V _{DD}	A1	-	supply voltage
V _{SSA(DLL)}	A2	-	analog ground for DLL of PPG
V _{DDA(DLL)}	A3	-	analog supply voltage for DLL of PPG
DISP_VSYNC	A4	O	digital vertical synchronization signal
IO1/IRQ17	A5	I/O	I/O port 0 bit 1 or interrupt request 17
V _{DDA(LCDG)}	A6	P	analog supply voltage for DAC component G
V _{DDA(OUTPUT2)}	A7	P	analog supply voltage for DAC video output 2

Table 3: Pin description...continued

Symbol	Pin	Type	Description
CREF_BG1	A8	-	band-gap 1
V _{SS(BG)}	A9	P	ground for BG of video DAC
SYSRSTIN	A10	I	system reset input/output; active LOW
V _{DD(RTC)}	A11	P	supply voltage for RTC
T0_CAP0	A12	I	timer 0 capture input 0
CNT2	A13	I	timer 2 count pulse input
CNT1	A14	I	timer 1 count pulse input
PWM0	A15	O	timer 0 PWM output
ADC0	A16	I	analog input signal 0 for level measurement
ADC3	A17	I	analog input signal 3 for level measurement
V _{SS(ADC)}	A18	P	ground for ADC
ANPPG1	B1	O	PPG analog signal 1
V _{DD}	B2	-	supply voltage
V _{SSA(DLL)}	B3	P	analog ground for DLL
IO6/IRQ22	B4	I/O	I/O port 0 bit 6 or interrupt request 22
IO3/IRQ19	B5	I/O	I/O port 0 bit 3 or interrupt request 19
LCD_G	B6	O	analog green signal
VIDEO_OUT2	B7	O	video output signal 2
V _{SSA(ref)}	B8	O	analog reference ground
SC_TCK	B9	I	test clock input for surround scan chains
TCK	B10	I	test clock input
XTALCCDOUT	B11	-	oscillator output from a specific CCD crystal
V _{DDA(SPLL)}	B12	P	analog supply voltage for SPLL
V _{SS(PLL)}	B13	P	ground for PLL
CNT0	B14	I	timer 0 count pulse input
V _{SSA(ref)(ADC)}	B15	O	analog reference ground for ADC
ADC2	B16	I	analog input signal 2 for level measurement
V _{DDA(ADC)}	B17	P	analog supply voltage for ADC
IO23	B18	I/O	I/O port 2 bit 7
V _{DDA(PPG1)}	C1	P	analog supply voltage for PPG
V _{DDA(PPG0)}	C2	P	analog supply voltage for PPG
V _{DDA(DLL)}	C3	P	analog supply voltage for DLL of PPG
IO7/IRQ23	C4	I/O	I/O port 0 bit 7 or interrupt request 23
IO4/IRQ20	C5	I/O	I/O port 0 bit 4 or interrupt request 20
LCD_R	C6	O	analog red signal
LCD_B	C7	O	analog blue signal
V _{DDA(OUTPUT1)}	C8	P	analog supply voltage for DAC video output 1
V _{DDA(BG)}	C9	P	analog supply voltage for BG of video DAC
TMS	C10	I	test mode select input
XTAL32KOUT	C11	-	oscillator output from a 32 kHz crystal
XTAL10OUT	C12	-	oscillator output from a 10 MHz crystal

Table 3: Pin description...continued

Symbol	Pin	Type	Description
GATE2	C13	I	timer 2 gate input
V _{DDA(PLL)}	C14	P	analog supply voltage for PLL
PWM1	C15	O	timer 1 PWM output
ADC1	C16	I	analog input signal 1 for level measurement
IO22	C17	I/O	I/O port 2 bit 6
IO16	C18	I/O	I/O port 2 bit 0
ANPPG7	D1	O	PPG analog signal 7
V _{SSA(PPG1)}	D2	P	analog ground for PPG
DISP_HSYNC	D3	O	digital horizontal synchronization signal
IO5/IRQ21	D4	I/O	I/O port 0 bit 5 or interrupt request 21
IO0/IRQ16	D5	I/O	I/O port 0 bit 0 or interrupt request 16
V _{SSA(LCD)}	D6	P	analog ground for display RGB
V _{SS(OUTPUT)}	D7	P	ground for DAC video output
CREF_BG2	D8	-	band-gap 2
TDO	D9	O	test data output
TDI	D10	I	test data input
V _{SS(RTC)}	D11	P	ground for RTC
XTAL10IN	D12	-	oscillator input from a 10 MHz crystal
T0_CAP1	D13	I	timer 0 capture input 1
GATE0	D14	I	timer 0 gate input
PWM2	D15	O	timer 2 PWM output
IO17	D16	I/O	I/O port 2 bit 1
IO15	D17	I/O	I/O port 1 bit 7
IO11	D18	I/O	I/O port 1 bit 3
PPG1	E1	O	PPG digital signal 0
PPG2	E2	O	PPG digital signal 1
ANPPG8	E3	O	PPG analog signal 8
V _{SSA(PPG0)}	E4	P	analog ground for PPG
IO2/IRQ18	E5	I/O	I/O port 0 bit 2 or interrupt request 18
V _{DDA(LCDR)}	E6	P	analog supply voltage for DAC component R
V _{DDA(LCDB)}	E7	P	analog supply voltage for DAC component B
VIDEO_OUT1	E8	O	video output signal 1
SYSRST	E9	O	system reset output; active LOW
TRST	E10	I	test reset input
VXTAL32KIN	E11	-	oscillator input from a 32 kHz crystal
XTALCCDIN	E12	-	oscillator input from a specific CCD crystal
V _{DD}	E13	-	supply voltage
GATE1	E14	I	timer 1 gate input
IO18	E15	I/O	I/O port 2 bit 2
IO10	E16	I/O	I/O port 1 bit 2
IO9	E17	I/O	I/O port 1 bit 1

Table 3: Pin description...continued

Symbol	Pin	Type	Description
UA_CLK	E18	I	UART external clock
PPG5	F1	O	PPG digital signal 4
PPG6	F2	O	PPG digital signal 5
PPG3	F3	O	PPG digital signal 2
ANPPG5	F4	O	PPG analog signal 5
ANPPG3	F5	O	PPG analog signal 3
V _{SS}	F6	-	ground
V _{SS}	F7	-	ground
V _{DD}	F8	-	supply voltage
V _{DD}	F9	-	supply voltage
V _{DD}	F10	-	supply voltage
V _{DD}	F11	-	supply voltage
V _{DD}	F12	-	supply voltage
IO20	F13	I/O	I/O port 2 bit 4
IO19	F14	I/O	I/O port 2 bit 3
IO12	F15	I/O	I/O port 1 bit 4
CTS	F16	I	UART clear to send
RXD	F17	I	UART receive input
TXD	F18	O	UART transmit output
PPG10	G1	O	PPG digital signal 17
PPG12	G2	O	PPG digital control signal 1
PPG8	G3	O	PPG digital signal 8
PPG4	G4	O	PPG digital signal 3
ANPPG6	G5	O	PPG analog signal 6
ANPPG2	G6	O	PPG analog signal 2
V _{DD}	G7	-	supply voltage
V _{SS}	G8	-	ground
V _{SS}	G9	-	ground
V _{SS}	G10	-	ground
V _{SS}	G11	-	ground
V _{DD}	G12	-	supply voltage
IO21	G13	I/O	I/O port 2 bit 5
IO13	G14	I/O	I/O port 1 bit 5
RTS	G15	O	UART request to send
SDA	G16	I/O	I ² C-bus data
SCL	G17	I/O	I ² C-bus clock
n.c.	G18	-	not connected
HDHREF	H1	I/O	PPG horizontal synchronization signal
VDVS	H2	I/O	PPG vertical synchronization signal
PPG13	H3	O	PPG digital control signal 2
PPG7	H4	O	PPG digital control signal 6

Table 3: Pin description...continued

Symbol	Pin	Type	Description
PPG14	H5	O	PPG digital control signal 3
ANPPG4	H6	O	PPG analog signal 4
V _{DD}	H7	-	supply voltage
V _{SS}	H8	-	ground
V _{SS}	H9	-	ground
V _{SS}	H10	-	ground
V _{SS}	H11	-	ground
V _{DD}	H12	-	supply voltage
IO14	H13	I/O	I/O port 1 bit 6
RXVPI	H14	I	USB
n.c.	H15	-	not connected
RXVMI	H16	I/O	USB
TXVPO	H17	O	USB
RXDATA	H18	I	USB
CCD_IM2	J1	I	digital image signal 2
CCD_IM3	J2	I	digital image signal 3
CCD_IM4	J3	I	digital image signal 4
PPG11	J4	O	PPG digital signal 18
PPG9	J5	O	PPG digital signal 8
V _{DD}	J6	-	supply voltage
V _{DD}	J7	-	supply voltage
V _{SS}	J8	-	ground
V _{SS}	J9	-	ground
V _{SS}	J10	-	ground
V _{SS}	J11	-	ground
V _{DD}	J12	-	supply voltage
IO8	J13	I/O	I/O port 1 bit 0
SUSPEND	J14	O	USB
TXOE	J15	O	USB
D2	J16	I/O	EBIU D2
D3	J17	I/O	EBIU D3
D0	J18	I/O	EBIU D0
CCD_IM10	K1	I	digital image signal 10
CCD_IM9	K2	I	digital image signal 9
CCD_IM8	K3	I	digital image signal 8
CCD_IM1	K4	I	digital image signal 1
CCD_IM0	K5	I	digital image signal 0
V _{DD}	K6	-	supply voltage
V _{DD}	K7	-	supply voltage
V _{SS}	K8	-	ground
V _{SS}	K9	-	ground

Table 3: Pin description...continued

Symbol	Pin	Type	Description
V _{SS}	K10	-	ground
V _{SS}	K11	-	ground
V _{DD}	K12	-	supply voltage
TXVMO	K13	O	USB
D1	K14	I/O	EBIU D1
D4	K15	I/O	EBIU D4
D6	K16	I/O	EBIU D6
D7	K17	I/O	EBIU D7
D8	K18	I/O	EBIU D8
SD_A[0]	L1	O	SDRAM controller address bus bit 0
SD_A[3]	L2	O	SDRAM controller address bus bit 3
SD_A[2]	L3	O	SDRAM controller address bus bit 2
CCD_IM6	L4	I	digital image signal 6
CCD_IM7	L5	I	digital image signal 7
CCD_IM5	L6	I	digital image signal 5
V _{DD}	L7	-	supply voltage
V _{SS}	L8	-	ground
V _{SS}	L9	-	ground
V _{SS}	L10	-	ground
V _{SS}	L11	-	ground
V _{DD}	L12	-	supply voltage
D5	L13	I/O	EBIU D5
D9	L14	I/O	EBIU D9
D11	L15	I/O	EBIU D11
D14	L16	I/O	EBIU D14
D13	L17	I/O	EBIU D13
D12	L18	I/O	EBIU D12
SD_A[7]	M1	O	SDRAM controller address bus bit 7
SD_A[8]	M2	O	SDRAM controller address bus bit 8
SD_A[9]	M3	O	SDRAM controller address bus bit 9
SD_A[4]	M4	O	SDRAM controller address bus bit 4
SD_A[1]	M5	O	SDRAM controller address bus bit 1
CCD_IM11	M6	I	digital image signal 11
V _{DD}	M7	-	supply voltage
V _{SS}	M8	-	ground
V _{SS}	M9	-	ground
V _{SS}	M10	-	ground
V _{SS}	M11	-	ground
V _{DD}	M12	-	supply voltage
D10	M13	I/O	EBIU D10
SC_SE	M14	O	EBIU controller \overline{SE} signal for SSFDC card; active LOW

Table 3: Pin description...continued

Symbol	Pin	Type	Description
D15	M15	I/O	EBIU D15
$\overline{\text{PC_WAIT2}}$	M16	I	EBIU controller WAIT signal for PC card 2; active LOW
$\overline{\text{SC_CE}}$	M17	O	EBIU controller $\overline{\text{CE}}$ signal for SSFDC card; active LOW
SC_CLE	M18	O	EBIU controller CLE signal for SSFDC card
SD_A[12]	N1	O	SDRAM controller address bus bit 12
SD_A[13]	N2	O	SDRAM controller address bus bit 13
SD_A[14]	N3	O	SDRAM controller address bus bit 14
SD_A[10]	N4	O	SDRAM controller address bus bit 10
SD_A[6]	N5	O	SDRAM controller address bus bit 6
SD_A[5]	N6	O	SDRAM controller address bus bit 5
V _{DD}	N7	-	supply voltage
V _{DD}	N8	-	supply voltage
V _{DD}	N9	-	supply voltage
V _{DD}	N10	-	supply voltage
V _{DD}	N11	-	supply voltage
SC_ALE	N12	O	EBIU controller ALE signal for SSFDC card
$\overline{\text{PC2_CE1}}$	N13	O	EBIU controller CE1 signal for PC card 2; active LOW
$\overline{\text{PC2_CE2}}$	N14	O	EBIU controller CE2 signal for PC card 2; active LOW
PC_REG	N15	O	EBIU controller REG signal for PC cards; active LOW
$\overline{\text{PC_WAIT1}}$	N16	O	EBIU controller WAIT signal for PC card 1; active LOW
$\overline{\text{IOWR_WE}}$	N17	O	EBIU controller IORD signal for PC cards; active LOW
$\overline{\text{IORD_RE}}$	N18	O	EBIU controller IORD signal for PC cards; active LOW
SD_CLKOUT	P1	O	SDRAM controller clock output
SD_CLKIN	P2	I	SDRAM controller clock input
$\overline{\text{SD_CS2}}$	P3	O	SDRAM controller chip select for memory 2; active LOW
SD_CLKEN	P4	O	SDRAM controller clock enable
SD_A[11]	P5	O	SDRAM controller address bus bit 11
V _{DD}	P6	-	supply voltage
SD_D[7]	P7	I/O	SDRAM controller data bus bit 7
IO25	P8	I/O	I/O port 3 bit 1
IO38	P9	I/O	I/O port 4 bit 6
A25	P10	I/O	EBIU A25 (Strapin[0] during boot sequence)
A21	P11	I/O	EBIU A21 (Strapin[4] during boot sequence)
V _{DD}	P12	-	supply voltage
A14	P13	I/O	EBIU A14
SCLK	P14	O	EBIU controller clock signal for external peripherals
A9	P15	I/O	EBIU A9
$\overline{\text{CAS0}}$	P16	O	EBIU controller CAS signal for DRAM memory for lower byte; used as data strobe signal for lower byte for general chip select; active LOW
$\overline{\text{PC1_CE1}}$	P17	O	EBIU controller CE1 signal for PC card 1; active LOW
$\overline{\text{PC1_CE2}}$	P18	O	EBIU controller CE2 signal for PC card 1; active LOW

Table 3: Pin description...continued

Symbol	Pin	Type	Description
SD_CS0	R1	O	SDRAM controller chip select for memory 0; active LOW
SD_CS1	R2	O	SDRAM controller chip select for memory 1; active LOW
SD_CS3	R3	O	SDRAM controller chip select for memory 3; active LOW
SD_D[4]	R4	I/O	SDRAM controller data bus bit 4
SD_RAS	R5	O	SDRAM controller row address strobe; active LOW
SD_D[6]	R6	I/O	SDRAM controller data bus bit 6
SD_D[13]	R7	I/O	SDRAM controller data bus bit 13
IO30	R8	I/O	I/O port 3 bit 6
IO37	R9	I/O	I/O port 4 bit 5
A24	R10	I/O	EBIU A24 (Strapin[1] during boot sequence)
A19	R11	I/O	EBIU A19 (Strapin[6] and Strapin[9] during boot sequence)
A18	R12	I/O	EBIU A18 (Strapin[10] during boot sequence)
A13	R13	I/O	EBIU A13
A5	R14	O	EBIU A5
CS6	R15	O	EBIU controller chip select 6; active LOW
CAS1	R16	O	EBIU controller CAS signal for DRAM memory for upper byte; used as data strobe signal for upper byte for general chip select; active LOW
OE	R17	O	EBIU controller output enable signal; active LOW
RAS	R18	O	EBIU controller RAS signal for DRAM memory; active LOW
SD_CAS	T1	O	SDRAM controller column address strobe; active LOW
SD_WE	T2	O	SDRAM controller write enable; active LOW
SD_D[3]	T3	I/O	SDRAM controller data bus bit 3
SD_D[8]	T4	I/O	SDRAM controller data bus bit 8
SD_D[10]	T5	I/O	SDRAM controller data bus bit 10
SD_D[14]	T6	I/O	SDRAM controller data bus bit 14
IO26	T7	I/O	I/O port 3 bit 2
IO29	T8	I/O	I/O port 3 bit 5
IO33	T9	I/O	I/O port 4 bit 1
IO36	T10	I/O	I/O port 4 bit 4
A23	T11	I/O	EBIU A23 (Strapin[2] during boot sequence)
A16	T12	I/O	EBIU A16
A12	T13	I/O	EBIU A12
A3	T14	O	EBIU A3
CS7	T15	O	EBIU controller chip select 7; active LOW
CS4	T16	O	EBIU controller chip select 4; active LOW
WE	T17	O	EBIU controller write enable signal; active LOW
CS_WAIT	T18	O	EBIU controller wait signal for chip selects; active LOW
SD_DQM0	U1	O	SDRAM controller DQ mask enable for byte 0; active LOW
SD_DQM1	U2	O	SDRAM controller DQ mask enable for byte 1; active LOW
SD_D[2]	U3	I/O	SDRAM controller data bus bit 2
SD_D[9]	U4	I/O	SDRAM controller data bus bit 9

Table 3: Pin description...continued

Symbol	Pin	Type	Description
SD_D[11]	U5	I/O	SDRAM controller data bus bit 11
SD_D[15]	U6	I/O	SDRAM controller data bus bit 15
IO27	U7	I/O	I/O port 3 bit 3
IO32	U8	I/O	I/O port 4 bit 0
IO34	U9	I/O	I/O port 4 bit 2
A22	U10	I/O	EBIU A22 (Strapin[3] during boot sequence)
A17	U11	I/O	EBIU A17 (Strapin[11] during boot sequence)
A11	U12	I/O	EBIU A11
A8	U13	I/O	EBIU A8
A4	U14	O	EBIU A4
A2	U15	O	EBIU A2
$\overline{\text{CS}}_5$	U16	O	EBIU controller chip select 5; active LOW
$\overline{\text{CS}}_3$	U17	O	EBIU controller chip select 3; active LOW
$\overline{\text{CS}}_0$	U18	O	EBIU controller chip select 0; active LOW
SD_D[0]	V1	I/O	SDRAM controller data bus bit 0
SD_D[1]	V2	I/O	SDRAM controller data bus bit 1
SD_D[5]	V3	I/O	SDRAM controller data bus bit 5
SD_D[12]	V4	I/O	SDRAM controller data bus bit 12
IO24	V5	I/O	I/O port 3 bit 0
IO28	V6	I/O	I/O port 3 bit 4
IO31	V7	I/O	I/O port 3 bit 7
IO35	V8	I/O	I/O port 4 bit 3
IO39	V9	I/O	I/O port 4 bit 7
A20	V10	I/O	EBIU A20 (Strapin[5] and Strapin[8] during boot sequence)
A15	V11	I/O	EBIU A15
A10	V12	I/O	EBIU A10
A7	V13	I/O	EBIU A7
A6	V14	I/O	EBIU A6
A1	V15	O	EBIU A1
A0	V16	O	EBIU A0
$\overline{\text{CS}}_2$	V17	O	EBIU controller chip select 2; active LOW
$\overline{\text{CS}}_1$	V18	O	EBIU controller chip select 1; active LOW

7. Limiting values

Table 4: Limiting values

In accordance with the Absolute Maximum Rating System (IEC 60134).

Symbol	Parameter	Conditions	Min	Max	Unit
V _{DDD}	digital supply voltage		-0.5	4	V
V _{DDA}	analog supply voltage		-0.5	4	V
V _I	DC input voltage	general	[1] [2]	-0.5	V _{DD} + 0.5 V
		5 V tolerant cells only	[2] [3]	-0.5	-0.5 V
I _{DD}	DC supply current per supply pin		[4]	-	60 mA
I _{SS}	DC ground current per ground pin		[4]	-	60 mA
T _{stg}	storage temperature		[5]	0	125 °C

[1] Value may not exceed 4 V.

[2] Including voltage on outputs in 3-state mode.

[3] Only valid when supply voltage is present.

[4] The peak current is limited to 10 times the corresponding maximum current.

[5] Dependent of package and not yet determined.

8. Characteristics

Table 5: General supply characteristics

Symbol	Parameter	Conditions	Min	Typ	Max	Unit
V _{DDD}	digital supply voltage		3.0	3.3	3.6	V
V _{DDA(DLL)}	analog supply voltage for DLL		3.0	3.3	3.6	V
V _{DDA(LCDDR)}	analog supply voltage for LCDDR output of DAC		3.0	3.3	3.6	V
V _{DDA(LCDG)}	analog supply voltage for LCDG output of DAC		3.0	3.3	3.6	V
V _{DDA(LCDB)}	analog supply voltage for LCDB		3.0	3.3	3.6	V
V _{DDA(OUTPUT1)}	analog supply voltage for video output 1 of DAC		3.0	3.3	3.6	V
V _{DDA(OUTPUT2)}	analog supply voltage for video output 2 of DAC		3.0	3.3	3.6	V
V _{DDA(ADC)}	analog supply voltage for ADC		3.0	3.3	3.6	V
V _{DDA(PPG1)}	analog supply voltage for PPG		3.0	3.3	3.6	V
V _{DDA(PPG0)}	analog supply voltage for PPG		3.0	3.3	3.6	V
V _{DDA(BG)}	analog supply voltage for bandgap		3.0	3.3	3.6	V
V _{DDA(PLL)}	analog supply voltage for PLL		3.0	3.3	3.6	V
V _{DDA(SPLL)}	analog supply voltage for SPLL		3.0	3.3	3.6	V
V _{DDD(RTC)}	digital supply voltage for RTC		[1] 3.0	3.3	3.6	V

[1] V_{DDD(RTC)} is the single supply which may be on when the others are off. In this case the I/Os of the SAA8122A have to be at 0 V.

Table 6: Operating characteristics

Symbol	Parameter	Conditions	Min	Typ	Max	Unit
V _{DDA(LCDR)}	analog supply voltage for LCDR output of DAC		3.0	3.3	3.6	V
V _{DDA(LCDG)}	analog supply voltage for LCDG output of DAC		3.0	3.3	3.6	V
V _{DDA(LCDB)}	analog supply voltage for LCDB output of DAC		3.0	3.3	3.6	V
V _{DDA(OUTPUT1)}	analog supply voltage for video output 1 of DAC		3.0	3.3	3.6	V
V _{DDA(OUTPUT2)}	analog supply voltage for video output 2 of DAC		3.0	3.3	3.6	V
V _{DDA(BG)}	analog supply voltage for bandgap		3.0	3.3	3.6	V
V _{BG}	bandgap reference voltage	(4 σ)	1.18	1.22	1.26	V
V _{OL}	LOW-level output voltage	code 0	-	0.225	-	V
V _{OH}	HIGH-level output voltage	code 511	-	1.625	-	V
LCD channels (1 kΩ buffer)						
R _L	load resistance		-	1	-	k Ω
C _L	load capacitance		-	-	5	pF
RES	resolution		-	8	-	bit
LCD channels (75 Ω mode)						
R _L	load resistance		-	75	-	Ω
C _L	load capacitance		-	5	100	pF
RES	resolution		-	9	-	bit
VIDEO_OUT channels (1 kΩ buffer)						
R _L	load resistance		-	1	-	k Ω
C _L	load capacitance		-	-	5	pF
RES	resolution		-	8	-	bit
VIDEO_OUT channels (1 kΩ mode)						
R _L	load resistance		-	1	-	k Ω
C _L	load capacitance		-	-	5	pF
RES	resolution		-	9	-	bit
ADC						
V _{DDA(ADC)}	analog supply voltage for analog ADC		3.0	3.3	3.6	V
Δ V _{DD}	supply voltage difference between V _{DDA} and V _{DDA(ADC)}		-	-	0.2	V
RES	resolution		8	-	10	bit
C _i	input capacitance		-	2	-	pF
V _i	input voltage		0	-	3.3	V
f _{sample}	sample frequency	8-bit	0	-	100	kHz
PLL						
V _{DDA(PLL)}	analog supply voltage for analog PLL		3.0	3.3	3.6	V

Table 6: Operating characteristics...continued

Symbol	Parameter	Conditions	Min	Typ	Max	Unit
ΔV_{DD}	supply voltage difference between V_{DDA} and $V_{DDA(PLL)}$		-	-	0.2	V
f_{clk}	clock frequency		-	96	-	MHz
SPLL						
$V_{DDA(SPLL)}$	analog supply voltage for analog SPLL		3.0	3.3	3.6	V
ΔV_{DD}	supply voltage difference between V_{DDA} and $V_{DDA(SPLL)}$		-	-	0.2	V
Power-on reset						
V_{trip}	trip level of power-on reset		1.5	2.07	2.65	V
t_{HIGH}	time that V_{DDA} has to be above 2.65 V before internal reset signal is asserted		-	-	2	μ s
t_{LOW}	time that V_{DDA} has to be above 2.65 V before internal reset signal is de-asserted		-	-	8	μ s
Analog PPG						
$V_{DDA(DLL)}$	analog supply voltage for analog DLL		3.0	3.3	3.6	V
$\Delta V_{DD-DDA(DLL)}$	supply voltage difference between V_{DDA} and $V_{DDA(DLL)}$		-	-	0.2	V
$V_{DDA(PPG1)}$; $V_{DDA(PPG0)}$	analog supply voltage for analog PPG		3.0	3.3	3.6	V
$\Delta V_{DD-DDA(PPG)}$	supply voltage difference between V_{DDA} and $V_{DDA(PPG1)}$ or $V_{DDA(PPG0)}$		-	-	0.2	V
I/Os ($V_{DDD} = V_{DDA}$, $T_{amb} = 0$ to 60 °C)						
Data and control inputs						
<i>SD_CLKIN</i>						
V_{IL}	LOW-level digital input voltage		0	-	$0.3V_{DDD}$	V
V_{IH}	HIGH-level digital input voltage		$0.7V_{DDD}$	-	V_{DDD}	V
C_i	input capacitance		-	1.14	-	pF
I_{IL}	LOW-level input current	$V_I = 0$ V	-	-	1	μ A
I_{IH}	HIGH-level input current	$V_I = V_{DDD}$	-	-	1	μ A
$I_{lu(I/O)}$	I/O latch-up current	$-0.5 < V_{DDD} < 0.5$	100	-	-	mA
<i>CS_WAIT, PC_WAIT1, PC_WAIT2, SC_TCK, TCK, TDI, TMS, TRST, CCD_IM0 to CCD_IM11, CNT0 to CNT2, GATE0 to GATE2, T0_CAP0, T0_CAP1, CTS, RXD, UA_CLK, RXDATA, RXVMI, RXVPI</i>						
V_{IL}	LOW-level digital input voltage		0	-	0.8	V
V_{IH}	HIGH-level digital input voltage		2.0	-	5.5	V
C_i	input capacitance		-	1.2	-	pF
I_{IL}	LOW-level input current	$V_I = 0$ V	-	-	1	μ A
I_{IH}	HIGH-level input current	$V_I = V_{DDD}$	-	-	1	μ A
$I_{lu(I/O)}$	I/O latch-up current	$-0.5 < V_{DDD} < 5.5$	100	-	-	mA
<i>SYSRSTIN</i>						
V_{IL}	LOW-level digital input voltage		0	-	0.8	V

Table 6: Operating characteristics...continued

Symbol	Parameter	Conditions	Min	Typ	Max	Unit
V_{IH}	HIGH-level digital input voltage		2.0	-	5.5	V
V_{hys}	hysteresis voltage		0.4	-	-	V
C_i	input capacitance		-	1.2	-	pF
I_{IL}	LOW-level input current	$V_I = 0\text{ V}$	-	-	1	μA
I_{IH}	HIGH-level input current	$V_I = V_{DDD}$	-	-	1	μA
$I_{lu(I/O)}$	I/O latch-up current	$-0.5 < V_{DDD} < 5.5$	100	-	-	mA
Data and control outputs						
<i>ANPPG1 to ANPPG8</i>						
V_{OL}	LOW-level digital output voltage	$I_{OL} = 4\text{ mA}$	0	-	0.4	V
V_{OH}	HIGH-level digital output voltage	$I_{OH} = 4\text{ mA}$	$V_{DDA} - 0.4$	-	V_{DDA}	V
$C_{o(L)(max)}$	maximum output load capacitance		[1] -	-	100	pF
I_{OL}	LOW-level output current	$V_{OL} = 0.4\text{ V};$ $V_{OH} = V_{DDA} - 0.4$	4	-	-	mA
I_{OH}	HIGH-level output current	$V_{OH} = V_{DDA} - 0.4$	-4	-	-	mA
<i>SCLK, SD_A[0] to SD_A[14], SD_CAS, SD_CLKEN, SD_CLKOUT, SD_CS0 to SD_CS3, SD_DQM0 to SD_DQM1, SD_RAS, SD_WE</i>						
V_{OL}	LOW-level digital output voltage	$I_{OL} = 4\text{ mA}$	0	-	0.4	V
V_{OH}	HIGH-level digital output voltage	$I_{OH} = -4\text{ mA}$	$V_{DDD} - 0.4$	-	V_{DDD}	V
C_i	input capacitance	-	-	1	-	pF
$C_{o(L)(max)}$	maximum output load capacitance	-	[1] -	-	100	pF
I_{OL}	LOW-level output current	$V_{OL} = 0.4\text{ V}$	-	-	-	μA
I_{OH}	HIGH-level output current	$V_{OH} = V_{DDD} - 0.4$	-4	-	-	mA
I_{OZ}	3-state output leakage current	$V_O = 0;$ $V_O = V_{DDD}$	-	-	1	μA
<i>TDO, SYSRST, PWM0 to PWM2, RTS, TXD, SUSPEND, TXOE, TXVMO, TXVPO, DISP_HSYNC, DISP_VSYNC</i>						
V_{OL}	LOW-level digital output voltage	$I_{OL} = 2\text{ mA}$	0	-	0.4	V
V_{OH}	HIGH-level digital output voltage	$I_{OH} = -2\text{ mA}$	$V_{DDD} - 0.4$	-	V_{DDD}	V
C_i	input capacitance	-	-	2.2	-	pF
$C_{o(L)(max)}$	maximum output load capacitance	-	[1] -	-	30	pF
I_{OL}	LOW-level output current	$V_{OL} = 0.4\text{ V};$ $V_{OH} = V_{DDD} - 0.4$	2	-	-	mA
I_{OH}	HIGH-level output current	$V_{OH} = V_{DDD} - 0.4$	-2	-	-	mA
I_{OZ}	3-state output leakage current	$V_O = 0;$ $V_O = V_{DD}$	-	-	1	μA
<i>CAS0, CAS1, CS0 to CS7, IORD_RE, IOWR_WE, OE, PC_REG, PC1_CE1, PC1_CE2, RAS, SC_ALE, SC_SE, WE, PPG1 to PPG14</i>						
V_{OL}	LOW-level digital output voltage	$I_{OL} = 4\text{ mA}$	0	-	0.4	V
V_{OH}	HIGH-level digital output voltage	$I_{OH} = -4\text{ mA}$	$V_{DDD} - 0.4$	-	V_{DDD}	V
C_i	input capacitance	-	-	2.4	-	pF
$C_{o(L)(max)}$	maximum output load capacitance	-	[1] -	-	30	pF
I_{OL}	LOW-level output current	$V_{OL} = 0.4\text{ V};$ $V_{OH} = V_{DDD} - 0.4$	4	-	-	mA
I_{OH}	HIGH-level output current	$V_{OH} = V_{DDD} - 0.4$	-4	-	-	mA

Table 6: Operating characteristics...continued

Symbol	Parameter	Conditions	Min	Typ	Max	Unit
I _{OZ}	3-state output leakage current	V _O = 0; V _O = V _D DD	-	-	1	μA
Data and control I/Os						
<i>SD_D[0] to SD_D[15]</i>						
V _{IL}	LOW-level digital input voltage	-	0	-	0.3V _D DD	V
V _{IH}	HIGH-level digital input voltage	-	0.7V _D DD	-	V _D DD	V
V _{OL}	LOW-level digital output voltage	I _{OL} = 4 mA	0	-	0.4	V
V _{OH}	HIGH-level digital output voltage	I _{OH} = -4 mA	V _D DD - 0.4	-	V _D DD	V
C _i	input capacitance	-	-	1.2	-	pF
C _{O(L)(max)}	maximum output load capacitance	-	[1]	-	100	pF
I _{OL}	LOW-level output current	V _{OL} = 0.4 V; V _{OH} = V _D DD - 0.4	4	-	-	mA
I _{OH}	HIGH-level output current	V _{OH} = V _D DD - 0.4	-4	-	-	mA
I _{OZ}	3-state output leakage current	V _O = 0; V _O = V _D DD	-	-	1	μA
I _{IL}	LOW-level input current	V _I = 0	-	-	1	μA
I _{IH}	HIGH-level input current	V _I = V _D DD	-	-	1	μA
<i>A0 to A15, IO8 to IO15, HDHREF, VDVS</i>						
V _{IL}	LOW-level digital input voltage	-	0	-	0.6V _D DD	V
V _{IH}	HIGH-level digital input voltage	-	0.7V _D DD	-	V _D DD	V
V _{OL}	LOW-level digital output voltage	I _{OL} = 4 mA	0	-	0.4	V
V _{OH}	HIGH-level digital output voltage	I _{OH} = -4 mA	V _D DD - 0.4	-	V _D DD	V
C _i	input capacitance	-	-	2.5	-	pF
C _{O(L)(max)}	maximum output load capacitance	-	[1]	-	30	pF
I _{OL}	LOW-level output current	V _{OL} = 0.4 V; V _{OH} = V _D DD - 0.4	4	-	-	mA
I _{OH}	HIGH-level output current	V _{OH} = V _D DD - 0.4	-4	-	-	mA
I _{OZ}	3-state output leakage current	V _O = 0; V _O = V _D DD	-	-	1	μA
I _{IL}	LOW-level input current	V _I = 0	-	-	1	μA
I _{IH}	HIGH-level input current	V _I = V _D DD	-	-	1	μA
<i>IO16 to IO23, IO0/IRQ16, IO1/IRQ17, IO2/IRQ18, IO3/IRQ19, IO4/IRQ20, IO5/IRQ21, IO6/IRQ22, IO7/IRQ23</i>						
V _{IL}	LOW-level digital input voltage	-	0	-	0.3V _D DD	V
V _{IH}	HIGH-level digital input voltage	-	0.7V _D DD	-	V _D DD	V
V _{OL}	LOW-level digital output voltage	I _{OL} = 2 mA	0	-	0.4	V
V _{OH}	HIGH-level digital output voltage	I _{OH} = -2 mA	V _D DD - 0.4	-	-	V
C _i	input capacitance	-	-	2.3	-	pF
C _{O(L)(max)}	maximum output load capacitance	-	-	-	30	pF
I _{OL}	LOW-level output current	V _{OL} = 0.4 V; V _{OH} = V _D DD - 0.4	2	-	-	mA
I _{OH}	HIGH-level output current	V _{OH} = V _D DD - 0.4	-2	-	-	mA

Table 6: Operating characteristics...continued

Symbol	Parameter	Conditions	Min	Typ	Max	Unit
I _{OZ}	3-state output leakage current	V _O = 0; V _O = V _{DDD}	-	-	1	μA
I _{IL}	LOW-level input current	V _I = 0	-	-	1	μA
I _{IH}	HIGH-level input current	V _I = V _{DDD}	-	-	1	μA
<i>IO4 to IO31</i>						
V _{IL}	LOW-level digital input voltage	-	0	-	0.8	V
V _{IH}	HIGH-level digital input voltage	-	2.0	-	5.5	V
V _{OL}	LOW-level digital output voltage	I _{OL} = 2 mA	-	-	0.4	V
V _{OH}	HIGH-level digital output voltage	I _{OH} = -2 mA	V _{DDD} - 0.4	-	V _{DDD}	V
C _i	input capacitance	-	-	1.5	-	pF
C _{o(L)(max)}	maximum output load capacitance	-	-	-	30	pF
I _{OL}	LOW-level output current	V _{OL} = 0.4 V; V _{OH} = V _{DDD} - 0.4	2	-	-	mA
I _{OH}	HIGH-level output current	V _{OH} = V _{DDD} - 0.4	-2	-	-	mA
I _{OZ}	3-state output leakage current	V _O = 0; V _O = V _{DDD}	-	-	1	μA
I _{IL}	LOW-level input current	V _I = 0	-	-	1	μA
I _{IH}	HIGH-level input current	V _I = V _{DDD}	-	-	1	μA
<i>IO32 to IO39</i>						
V _{IL}	LOW-level digital input voltage	-	0	-	0.8	V
V _{IH}	HIGH-level digital input voltage	-	2.0	-	5.5	V
V _{OL}	LOW-level digital output voltage	I _{OL} = 1 mA	0	-	0.4	V
V _{OH}	HIGH-level digital output voltage	I _{OH} = -1 mA	V _{DDD} - 0.4	-	V _{DDD}	V
C _i	input capacitance	-	-	1.4	-	pF
C _{o(L)(max)}	maximum output load capacitance	-	-	-	30	pF
I _{OL}	LOW-level output current	V _{OL} = 0.4 V; V _{OH} = V _{DDD} - 0.4	1	-	-	mA
I _{OH}	HIGH-level output current	V _{OH} = V _{DDD} - 0.4	-1	-	-	mA
I _{OZ}	3-state output leakage current	V _O = 0; V _O = V _{DDD}	-	-	1	μA
I _{IL}	LOW-level input current	V _I = 0	-	-	1	μA
I _{IH}	HIGH-level input current	V _I = V _{DDD}	-	-	1	μA
<i>I²C-bus I/Os</i>						
<i>SCL and SDA</i>						
V _{IL}	LOW-level digital input voltage	-	0	-	0.3V _{DDD}	V
V _{IH}	HIGH-level digital input voltage	-	0	-	0.3V _{DDD}	V
V _{hys}	hysteresis voltage	-	0.005V _{DDD}	-	-	V
V _{OL}	LOW-level digital output voltage	I _{OL} = 3 mA	-	-	0.4	V
C _i	input capacitance	-	-	3.2	-	pF
C _{o(L)(max)}	maximum output load capacitance	-	[1]	-	400	pF

Table 6: Operating characteristics...continued

Symbol	Parameter	Conditions	Min	Typ	Max	Unit
I _{OZ}	3-state output leakage	V _O = 0; V _O = V _{DDD}	-	-	1	μA
I _{IL}	LOW-level input current	V _I = 0	-	-	1	μA
I _{IH}	HIGH-level input current	V _I = V _{DDD}	-	-	1	μA

[1] The maximum capacitance value given does not take into account the signal frequency. For critical signals the maximum capacitance has to be weighted according to the signal frequency and external devices constraints.

9. Package outline

LFBGA324: plastic low profile fine-pitch ball grid array package; 324 balls; body 16 x 16 x 1.2 mm SOT571-1

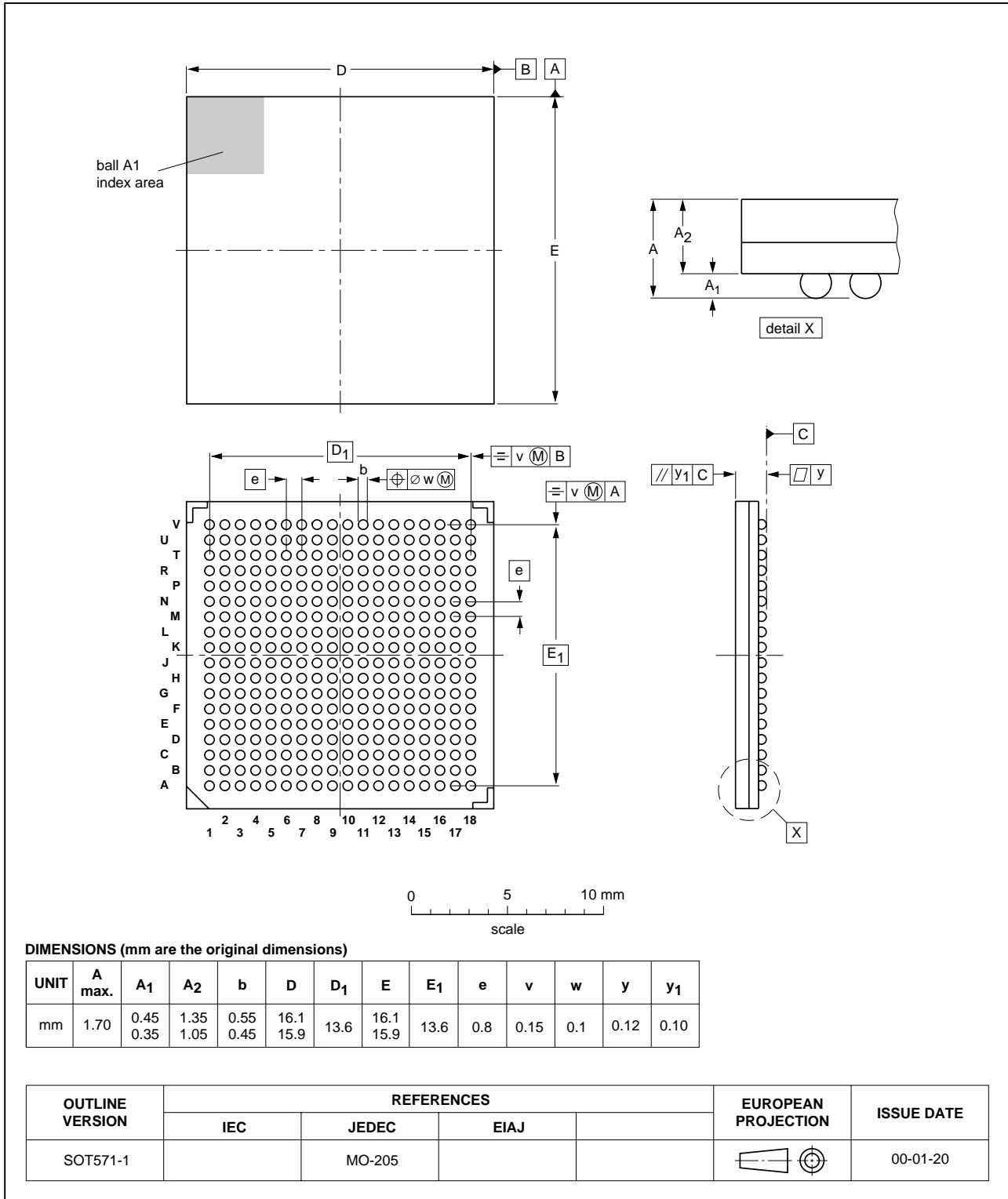

Fig 4. SOT571-1.

10. Soldering

10.1 Introduction to soldering surface mount packages

This text gives a very brief insight to a complex technology. A more in-depth account of soldering ICs can be found in our *Data Handbook IC26; Integrated Circuit Packages* (document order number 9398 652 90011).

There is no soldering method that is ideal for all surface mount IC packages. Wave soldering can still be used for certain surface mount ICs, but it is not suitable for fine pitch SMDs. In these situations reflow soldering is recommended.

10.2 Reflow soldering

Reflow soldering requires solder paste (a suspension of fine solder particles, flux and binding agent) to be applied to the printed-circuit board by screen printing, stencilling or pressure-syringe dispensing before package placement.

Several methods exist for reflowing; for example, convection or convection/infrared heating in a conveyor type oven. Throughput times (preheating, soldering and cooling) vary between 100 and 200 seconds depending on heating method.

Typical reflow peak temperatures range from 215 to 250 °C. The top-surface temperature of the packages should preferably be kept below 220 °C for thick/large packages, and below 235 °C small/thin packages.

10.3 Wave soldering

Conventional single wave soldering is not recommended for surface mount devices (SMDs) or printed-circuit boards with a high component density, as solder bridging and non-wetting can present major problems.

To overcome these problems the double-wave soldering method was specifically developed.

If wave soldering is used the following conditions must be observed for optimal results:

- Use a double-wave soldering method comprising a turbulent wave with high upward pressure followed by a smooth laminar wave.
- For packages with leads on two sides and a pitch (e):
 - larger than or equal to 1.27 mm, the footprint longitudinal axis is **preferred** to be parallel to the transport direction of the printed-circuit board;
 - smaller than 1.27 mm, the footprint longitudinal axis **must** be parallel to the transport direction of the printed-circuit board.

The footprint must incorporate solder thieves at the downstream end.

- For packages with leads on four sides, the footprint must be placed at a 45° angle to the transport direction of the printed-circuit board. The footprint must incorporate solder thieves downstream and at the side corners.

During placement and before soldering, the package must be fixed with a droplet of adhesive. The adhesive can be applied by screen printing, pin transfer or syringe dispensing. The package can be soldered after the adhesive is cured.

Typical dwell time is 4 seconds at 250 °C. A mildly-activated flux will eliminate the need for removal of corrosive residues in most applications.

10.4 Manual soldering

Fix the component by first soldering two diagonally-opposite end leads. Use a low voltage (24 V or less) soldering iron applied to the flat part of the lead. Contact time must be limited to 10 seconds at up to 300 °C.

When using a dedicated tool, all other leads can be soldered in one operation within 2 to 5 seconds between 270 and 320 °C.

10.5 Package related soldering information

Table 7: Suitability of surface mount IC packages for wave and reflow soldering methods

Package	Soldering method	
	Wave	Reflow ^[1]
BGA, HBGA, LFBGA, SQFP, TFBGA	not suitable	suitable
HBCC, HLQFP, HSQFP, HSOP, HTQFP, HTSSOP, HVQFN, SMS	not suitable ^[2]	suitable
PLCC ^[3] , SO, SOJ	suitable	suitable
LQFP, QFP, TQFP	not recommended ^{[3][4]}	suitable
SSOP, TSSOP, VSO	not recommended ^[5]	suitable

- [1] All surface mount (SMD) packages are moisture sensitive. Depending upon the moisture content, the maximum temperature (with respect to time) and body size of the package, there is a risk that internal or external package cracks may occur due to vaporization of the moisture in them (the so called popcorn effect). For details, refer to the Drypack information in the *Data Handbook IC26; Integrated Circuit Packages; Section: Packing Methods*.
- [2] These packages are not suitable for wave soldering as a solder joint between the printed-circuit board and heatsink (at bottom version) can not be achieved, and as solder may stick to the heatsink (on top version).
- [3] If wave soldering is considered, then the package must be placed at a 45° angle to the solder wave direction. The package footprint must incorporate solder thieves downstream and at the side corners.
- [4] Wave soldering is only suitable for LQFP, QFP and TQFP packages with a pitch (e) equal to or larger than 0.8 mm; it is definitely not suitable for packages with a pitch (e) equal to or smaller than 0.65 mm.
- [5] Wave soldering is only suitable for SSOP and TSSOP packages with a pitch (e) equal to or larger than 0.65 mm; it is definitely not suitable for packages with a pitch (e) equal to or smaller than 0.5 mm.

11. Revision history

Table 8: Revision history

Rev	Date	CPCN	Description
03	20001122		Objective specification; third version. Modification: <ul style="list-style-type: none">• Added disclaimer for ICs with JPEG functionality.
02	20001002	-	Objective specification; second version. Modifications: <ul style="list-style-type: none">• Table 3 "Pin description": changed pin mnemonics and description.
01	20000420	-	Objective specification; initial version

12. Data sheet status

Datasheet status	Product status	Definition ^[1]
Objective specification	Development	This data sheet contains the design target or goal specifications for product development. Specification may change in any manner without notice.
Preliminary specification	Qualification	This data sheet contains preliminary data, and supplementary data will be published at a later date. Philips Semiconductors reserves the right to make changes at any time without notice in order to improve design and supply the best possible product.
Product specification	Production	This data sheet contains final specifications. Philips Semiconductors reserves the right to make changes at any time without notice in order to improve design and supply the best possible product.

[1] Please consult the most recently issued data sheet before initiating or completing a design.

13. Definitions

Short-form specification — The data in a short-form specification is extracted from a full data sheet with the same type number and title. For detailed information see the relevant data sheet or data handbook.

Limiting values definition — Limiting values given are in accordance with the Absolute Maximum Rating System (IEC 60134). Stress above one or more of the limiting values may cause permanent damage to the device. These are stress ratings only and operation of the device at these or at any other conditions above those given in the Characteristics sections of the specification is not implied. Exposure to limiting values for extended periods may affect device reliability.

Application information — Applications that are described herein for any of these products are for illustrative purposes only. Philips Semiconductors make no representation or warranty that such applications will be suitable for the specified use without further testing or modification.

14. Disclaimers

Life support — These products are not designed for use in life support appliances, devices, or systems where malfunction of these products can reasonably be expected to result in personal injury. Philips Semiconductors customers using or selling these products for use in such applications do so at their own risk and agree to fully indemnify Philips Semiconductors for any damages resulting from such application.

Right to make changes — Philips Semiconductors reserves the right to make changes, without notice, in the products, including circuits, standard cells, and/or software, described or contained herein in order to improve design and/or performance. Philips Semiconductors assumes no responsibility or liability for the use of any of these products, conveys no licence or title under any patent, copyright, or mask work right to these products, and makes no representations or warranties that these products are free from patent, copyright, or mask work right infringement, unless otherwise specified.

ICs with JPEG functionality — Purchase of a Philips IC with JPEG functionality does **not** convey an implied license under any patent right to use this IC in any JPEG application, e.g. digital still picture camera. A license can be obtained via the Philips Corporate Intellectual Property department. For more information please contact the nearest Philips Semiconductors sales office.

15. Licenses

Purchase of Philips I²C components



Purchase of Philips I²C components conveys a license under the Philips' I²C patent to use the components in the I²C system provided the system conforms to the I²C specification defined by Philips. This specification can be ordered using the code 9398 393 40011.

Philips Semiconductors - a worldwide company

Argentina: see South America

Australia: Tel. +61 2 9704 8141, Fax. +61 2 9704 8139

Austria: Tel. +43 160 101, Fax. +43 160 101 1210

Belarus: Tel. +375 17 220 0733, Fax. +375 17 220 0773

Belgium: see The Netherlands

Brazil: see South America

Bulgaria: Tel. +359 268 9211, Fax. +359 268 9102

Canada: Tel. +1 800 234 7381

China/Hong Kong: Tel. +852 2 319 7888, Fax. +852 2 319 7700

Colombia: see South America

Czech Republic: see Austria

Denmark: Tel. +45 3 288 2636, Fax. +45 3 157 0044

Finland: Tel. +358 961 5800, Fax. +358 96 158 0920

France: Tel. +33 14 099 6161, Fax. +33 14 099 6427

Germany: Tel. +49 40 23 5360, Fax. +49 402 353 6300

Hungary: see Austria

India: Tel. +91 22 493 8541, Fax. +91 22 493 8722

Indonesia: see Singapore

Ireland: Tel. +353 17 64 0000, Fax. +353 17 64 0200

Israel: Tel. +972 36 45 0444, Fax. +972 36 49 1007

Italy: Tel. +39 039 203 6838, Fax. +39 039 203 6800

Japan: Tel. +81 33 740 5130, Fax. +81 3 3740 5057

Korea: Tel. +82 27 09 1412, Fax. +82 27 09 1415

Malaysia: Tel. +60 37 50 5214, Fax. +60 37 57 4880

Mexico: Tel. +9-5 800 234 7381

Middle East: see Italy

For all other countries apply to: Philips Semiconductors,
Marketing Communications,
Building BE, P.O. Box 218, 5600 MD EINDHOVEN,
The Netherlands, Fax. +31 40 272 4825

Netherlands: Tel. +31 40 278 2785, Fax. +31 40 278 8399

New Zealand: Tel. +64 98 49 4160, Fax. +64 98 49 7811

Norway: Tel. +47 22 74 8000, Fax. +47 22 74 8341

Philippines: Tel. +63 28 16 6380, Fax. +63 28 17 3474

Poland: Tel. +48 22 5710 000, Fax. +48 22 5710 001

Portugal: see Spain

Romania: see Italy

Russia: Tel. +7 095 755 6918, Fax. +7 095 755 6919

Singapore: Tel. +65 350 2538, Fax. +65 251 6500

Slovakia: see Austria

Slovenia: see Italy

South Africa: Tel. +27 11 471 5401, Fax. +27 11 471 5398

South America: Tel. +55 11 821 2333, Fax. +55 11 829 1849

Spain: Tel. +34 33 01 6312, Fax. +34 33 01 4107

Sweden: Tel. +46 86 32 2000, Fax. +46 86 32 2745

Switzerland: Tel. +41 14 88 2686, Fax. +41 14 81 7730

Taiwan: Tel. +886 22 134 2451, Fax. +886 22 134 2874

Thailand: Tel. +66 23 61 7910, Fax. +66 23 98 3447

Turkey: Tel. +90 216 522 1500, Fax. +90 216 522 1813

Ukraine: Tel. +380 44 264 2776, Fax. +380 44 268 0461

United Kingdom: Tel. +44 208 730 5000, Fax. +44 208 754 8421

United States: Tel. +1 800 234 7381

Uruguay: see South America

Vietnam: see Singapore

Yugoslavia: Tel. +381 11 3341 299, Fax. +381 11 3342 553

Internet: <http://www.semiconductors.philips.com>

(SCA70)

Contents

1	Description	1
2	Features	1
2.1	General	1
2.2	External interfaces	2
2.3	CPU related features	2
2.4	DSP features	2
2.5	Pulse pattern generator features	2
2.6	JPEG	2
2.7	USB interface	2
2.8	Card interfaces	3
2.9	Bus	3
2.10	SDRAM interface features	3
3	Quick reference data	3
4	Ordering information	3
5	Block diagram	4
6	Pinning information	5
6.1	Pinning	5
6.2	Pin description	5
7	Limiting values	14
8	Characteristics	14
9	Package outline	21
10	Soldering	22
10.1	Introduction to soldering surface mount packages	22
10.2	Reflow soldering	22
10.3	Wave soldering	22
10.4	Manual soldering	23
10.5	Package related soldering information	23
11	Revision history	24
12	Data sheet status	25
13	Definitions	25
14	Disclaimers	25
15	Licenses	25



PHILIPS

Let's make things better.